

# Micrometer

The origin of Mitutoyo's trustworthy brand of small tool instruments

## Can Seam Micrometers SERIES 147

- Measures the width, height, and depth of can seams.



147-103

### SPECIFICATIONS

Metric				
Order No.	Range (mm)	Graduation (mm)	Maximum permissible error $J_{MPE}$ ( $\mu\text{m}$ )	Remarks
147-103	0 - 13	0.01	$\pm 3$	for steel cans
147-105				for aluminum cans
147-202				for spray cans

Inch				
Order No.	Range (in)	Graduation (in)	Maximum permissible error $J_{MPE}$ (in)	Remarks
147-104	0 - 0.5	0.001	$\pm 0.00015$	for steel cans
147-106				for aluminum cans
147-201				for spray cans

### DIMENSIONS

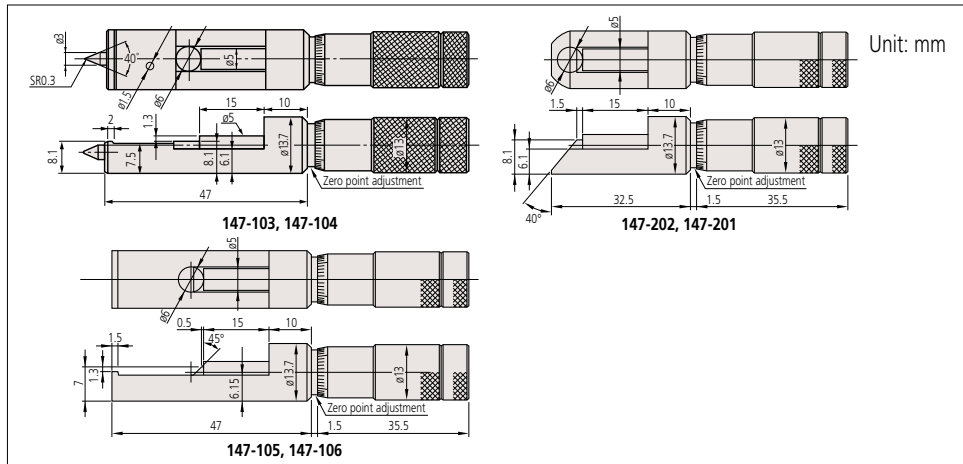

### Standard Accessories

- Spanner (200168), 1 pc.
- Spanner (202863), 1 pc.

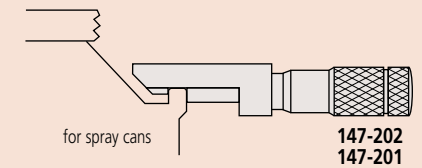
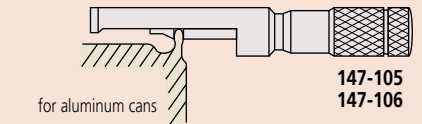
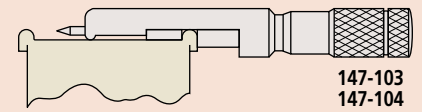

## Hub Micrometers SERIES 147

- Measures hub thickness and shoulders inside a bore.
- Measuring faces: Carbide.
- Equipped with Ratchet Stop for constant measuring force.



147-301

### SPECIFICATIONS

Metric			
Order No.	Range (mm)	Graduation (mm)	Maximum permissible error $J_{MPE}$ ( $\mu\text{m}$ )
147-301	0 - 25	0.01	$\pm 2$
147-302	25 - 50		
147-303	50 - 75		
147-304	75 - 100		$\pm 3$

Inch			
Order No.	Range (in)	Graduation (in)	Maximum permissible error $J_{MPE}$ (in)
147-351	0 - 1	0.001	$\pm 0.0001$
147-352	1 - 2		
147-353	2 - 3		
147-354	3 - 4		$\pm 0.00015$

### DIMENSIONS

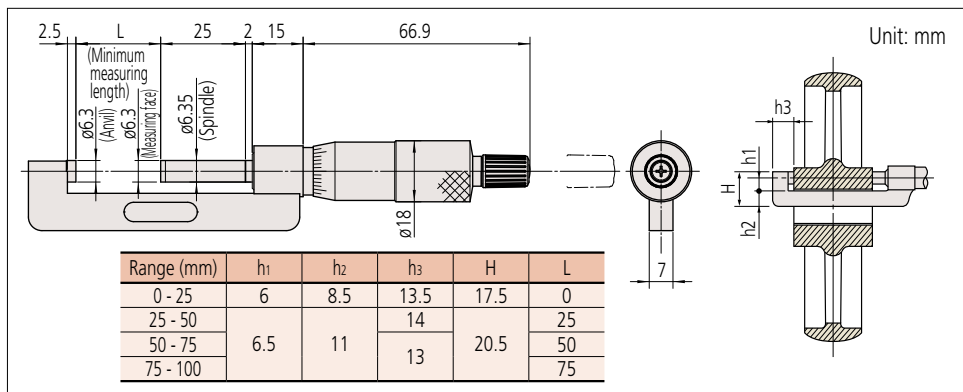

### Technical Data

- Flatness: 0.6  $\mu\text{m}$  / 0.000024 in
- Parallelism: 3  $\mu\text{m}$  / 0.00012 in



### Standard Accessories

- Reference bar, 1 pc. (except for measuring range 0 to 25 mm (0 to 1 in) models)
- Spanner (301336), 1 pc.